

REVO DATA ACQUISITION UNIT (DAU)

The REVO Data Acquisition Unit (DAU) series features an internal back plane with up to eight interchangeable cards to support rapid customisation and configuration for various applications.

The unit supports a dual channel configuration with redundant acquisition cards and redundant processing used to support higher integrity applications.

FPGA based processing coupled with high speed analog front ends allows both digital (e.g. ARINC-429) and analog (e.g. Synchro) signals to be measured with the same pins in different applications.

Total I/O capability is determined by exact card configurations and pin availability, e.g.

Expansion capabilities via internal daughter cards include:

- Differential (input): 48 channels
- Single Ended (input): 96 channels
- Transceivers: 6 channels
- Discrete Outputs: 2 channels
- Auxiliary Outputs: 4 protected 28VDC

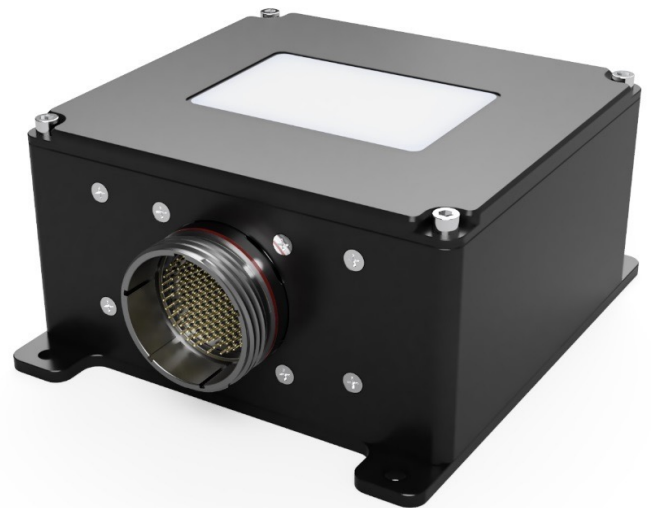
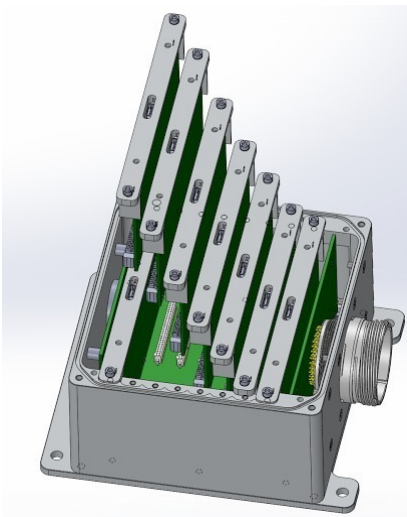

Card Types (exact configuration subject to installation requirements)		
Power and Transceiver Card	28VDC input with ARINC-429, ARINC-717, ARINC-825 transceivers	
Acquisition Card(s)	24 channel High Speed Differential	Programmable input ranges: +/- 40VDC, +/- 20VDC, +/- 10VDC, +/- 5VDC ADC Resolution: 16 bit (20 bit with oversampling) Sampling rate (per channel): 1000 kHz
	48 channel Single Ended	Input range: 0-40 VDC ADC Resolution: 10 bit Sampling rate (per channel): 100 Hz Programmable shunt discrete pullup: 400 uA Discrete type: Tristate (GND, Open, 28VDC) with switching hysteresis
	4 port Ethernet Switch	Only for use with Single FPGA and Microprocessor card. Includes Active Power over Ethernet capability.
	16 port Adaptive Bus	Two wire Power and Data
Processing Card(s)	Dual Channel FPGA with Monitor	
	Single FPGA with Microprocessor	Includes 2 gigabyte NAND for internal recording

Diagnostic Solutions International, LLC

ISO9001 & AS9100D Certified

2580 East Philadelphia Street, Unit C, Ontario, California 91761 USA

1.909.930.3600 Tel | 1.877.374.5521 Toll Free | dsi-hums.com



DIAGNOSTIC SOLUTIONS INTERNATIONAL LLC

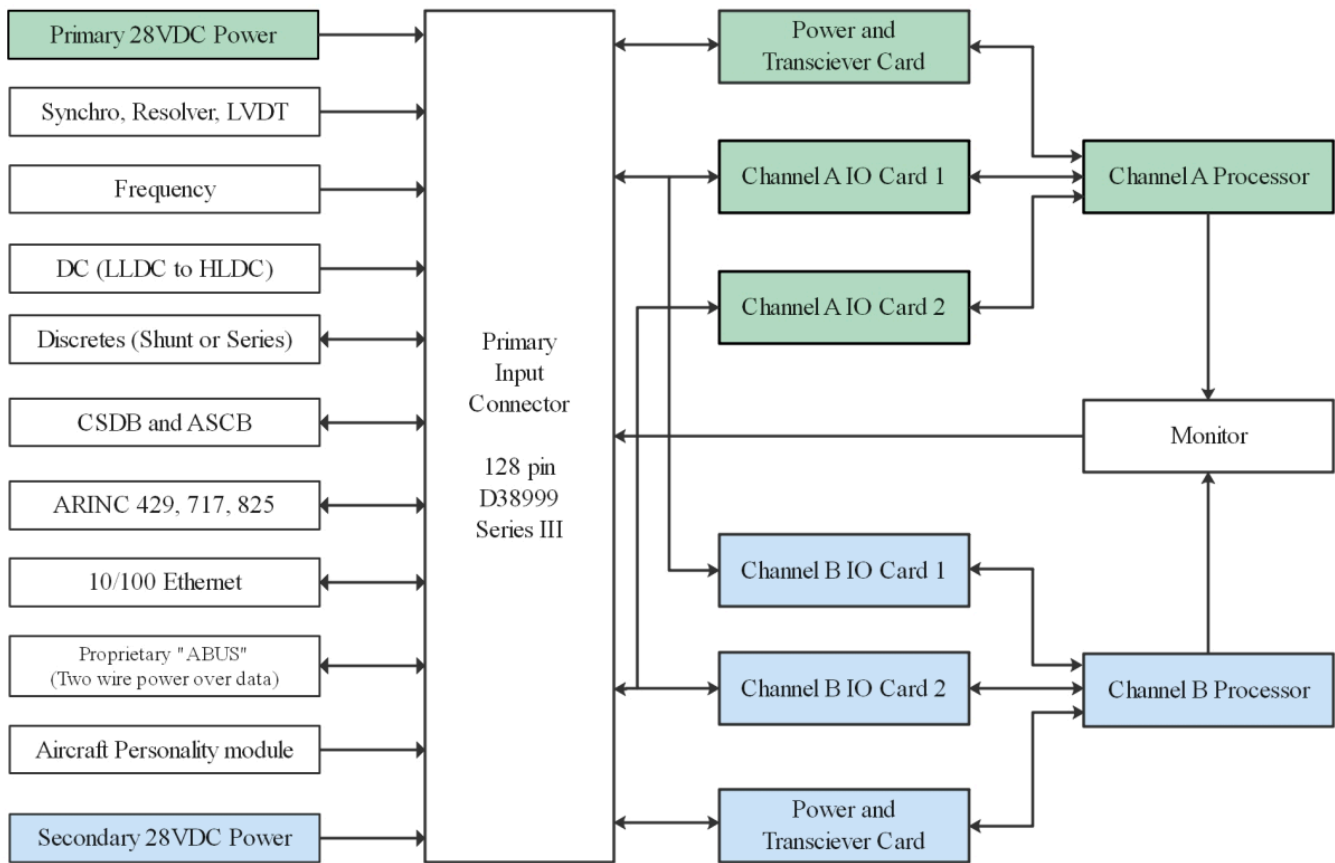

PHYSICAL AND ELECTRICAL SPECIFICATIONS	
Dimensions	133mm (5.3") width, 71mm (2.8") height, 154mm (6.1") depth
Weight	Less than 1kg (< 2.2 lbs)
Mounting Type	Flanged with Qty 4 #10 GPL fastener (e.g. NAS1352-3-10)
Mounting Orientation	Unrestricted
Construction	Aluminium AMS QQ-A-200/8, ASTM-B221
Finish	MIL-DTL-5541 Type II Class 3, painted subject to requirement (excluding faying surface)
Power supply input	Dual 28 VDC nominal, 10 to 80 VDC, DO-160 CAT Z
Power supply consumption	Maximum 10 watt (excluding inrush and external powered loads)
Power supply hold-up energy	5 seconds minimum
Input Connector	MIL-DTL-38999 Series III, D38999/20FJ35PN
Mating Connector	MIL-DTL-38999 Series III, D38999/26FJ35SN
Operating Temperature (operating)	-55 to +70 degrees Celcius
Operating Temperature (non-operating)	-55 to +85 degrees Celcius
Operating Altitude	Up to 55,000 ft
Environmental Qualification	RTCA DO-160G
Design Assurance	RTCA DO-254 and DO-178C (as applicable)
Production Approvals	FAA PMA (where PMA assist applies), otherwise Certificate of Conformance



**DIAGNOSTIC
SOLUTIONS
INTERNATIONAL LLC**

Diagnostic Solutions International, LLC

ISO9001 & AS9100D Certified

2580 East Philadelphia Street, Unit C, Ontario, California 91761 USA

1.909.930.3600 Tel | 1.877.374.5521 Toll Free | dsi-hums.com